



MagNet Challenge: people · magnetics · AI

Minjie Chen
Princeton University

Charles R. Sullivan
Dartmouth College



MagNet Community

Charles R. Sullivan



Technical Committee



Diego Serrano



Thomas Guillod



Haoran Li



Shukai Wang



Hyukjae Kwon



Hans Wouters

Judge Committee



David Perreault



Dragan Maksimović



Johann Kolar



Ron S. Y. Hui



Jürgen Biela



Matt Wilkowski

PELS & PSMA Friends

John G. Kassakian, Brad Lehman, Mike Kelly, Johan Eslin, Alan Mantooth, Matt Wilkowski, Stephanie Butler, Frede Blaabjerg, Patrick Wheeler, Gerard Hurley, Mario Pacas, Mark Dehong Xu, Peter Wilson, Mark G. Allen, Maeve Duffy, Liucheng Chang, Philip Krein, Khurram Afridi, Shuai Jiang, Houle Gan, David Schumacher, Kaladhar Radhakrishnan, Niraj Jha, Yuxin Chen, Brianna Fornaro, George Slama, Edward Herbert, Jens Schweickhardt, Ziwei Ouyang, Alex Hanson, Kevin Hermanns, Shirley Pei, Tom Gray, Victor Li, Sombuddha Chakraborty, Gerard Hurley, Martin Kuo, David Giuliano, Toshihisa Shimizu, Wei Chen, Jinjun Liu, Hans Wouter, Subham Sahoo, Miroslav Vasic, Brenda Mikeo, Mike Ranjram, Oliver Wallscheid, Sinan Li, Han Cui, Yanan Chen, Ping Wang, Wilmar Martinez, Subham Sahoo, Rafal Wojda...



MagNet Challenge 1&2



Universities:

- 12 US & Latin America
- 28 Asia & Pacific
- 18 Europe
- 0 Middle East or Africa

21

countries +

58

universities

80

teams

238+

participants

48

months

People · Magnetics · AI



21

countries

58

universities

80

teams

238+

participants

America (12 Universities):

- Princeton University*
- Dartmouth College*
- Georgia Institute of Technology*
- Arizona State University*
- University of Colorado Boulder*
- University of Missouri Columbia*
- University of Tennessee*
- Federal University of Santa Catarina*
- Purdue University
- Cornell University
- Northeastern University
- University of Wisconsin-Madison

Europe (18 Universities):

- Paderborn University*
- Siegen University*
- University of Kassel
- University of Cambridge*
- University of Bristol*
- University of Manchester*
- Aalborg University*
- TU Delft*
- Eindhoven University of Technology*
- KU Leuven*
- Politecnico di Torino*
- Mondragon University*
- Silicon Austria Labs*
- Universidad Politécnica de Madrid
- University of Nottingham
- University of Leeds
- TU Munich
- University of Twente

Asia (25 Universities)

- Tsinghua University*
- Zhejiang University*
- Zhejiang University-UIUC*
- Xi'an Jiaotong University*
- Southeast University*
- Tianjin University*
- Fuzhou University*
- Hangzhou Dianzi University*
- Hefei University of Technology*
- Fujian University of Technology*
- The Hong Kong Polytechnic University*
- City University of Hong Kong*
- Nanjing University of Posts and Telecommunications*
- Huazhong University of Science and Technology*
- University of Electronic Science and Technology of China*
- Jinan University
- Tokyo Metropolitan University*
- Nagoya Institute of Technology
- Indian Institute of Science*
- Indian Institute of Technology Dharwad*
- National Institute of Technology Calicut*
- Nanyang Technological University*
- National Taipei University of Technology*
- Tribhuvan University*
- Seoul National University

Oceania (3 Universities):

- University of Sydney*
- University of Technology Sydney*
- University of Auckland

* registered and finished the competition

Acknowledgements

Research



ARPAE™



U.S. National
Science Foundation

Admin



IEEE POWER
ELECTRONICS SOCIETY
Powering a Sustainable Future



PRINCETON
UNIVERSITY



Dartmouth

Sponsors



Magnetics & AI

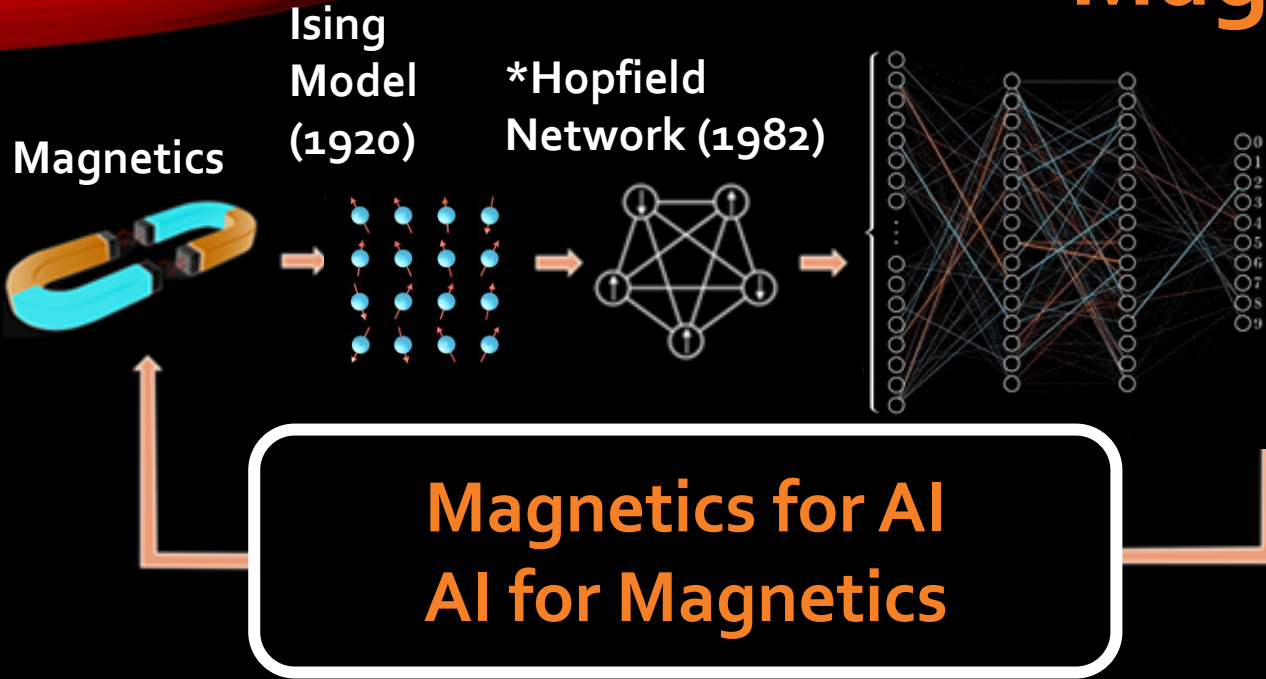

Back Propagation
*Hinton
(1986)

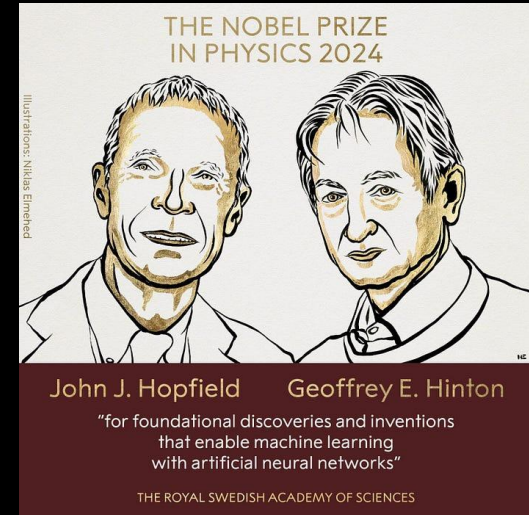

- Hopfield: Energy-based neural network (PNAS'82)
- Hinton: Back-propagation (Nature'86)

AI for Magnetics



ImageNet / CUDA

Physical Transformers

AI Transformers (GPT)

AlphaFold

Power for AI

1900

1980

2010

2017

2020

2022

2026

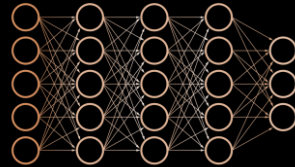

Early attempts on NN for magnetics

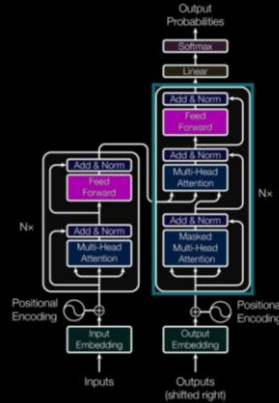

SSTs

IVRs

Magnetics for AI <> AI for Magnetics

Why AI for Magnetics?

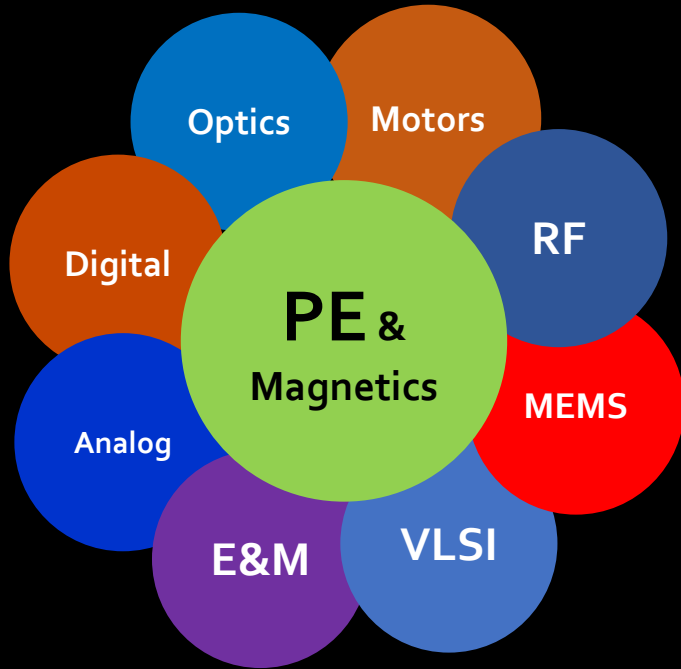

Responsibility

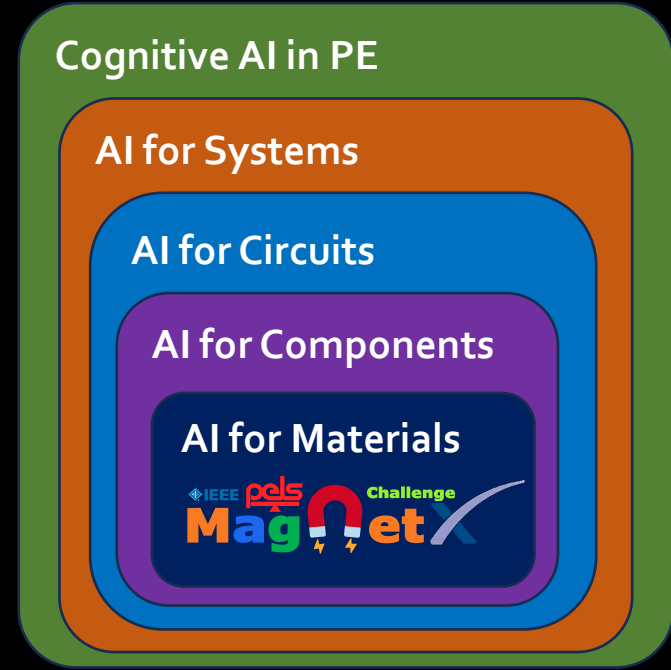

Opportunity

How AI for Magnetics?

Computer Vision

IMAGENET



Fei-Fei Li



Geoffrey Hinton

Power Magnetics



ImageNet / Nvidia-CUDA

AlexNet

Transformer

OpenClaw

2006

2010

2012

2016

2017

2022

2026

20 Years!

ImageNet Challenge

AlphaGo

ChatGPT

MagNet 0

MagNet 2

MagNet AI Agent ???

70% magnetics
designed by AI
by 2040 ? !!!

2020

2023

2025

2027

...

2040?

MagNet 1

MagNet 3

MagNet Challenge (MC)

MC1: Steady-State Loss

Steinmetz Equations (100 yrs old)

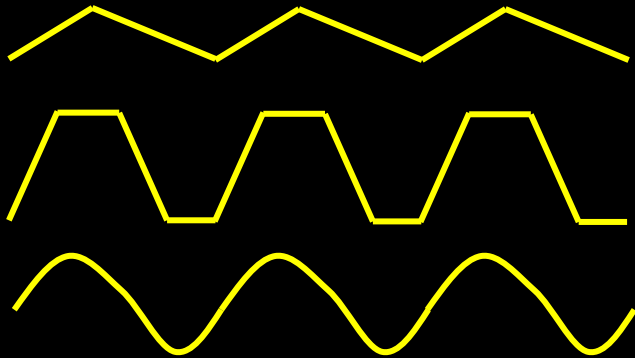

e.g., DCX / IVR

MC2: Transient Dynamics

Preisach and J-A Models (50 yrs old)

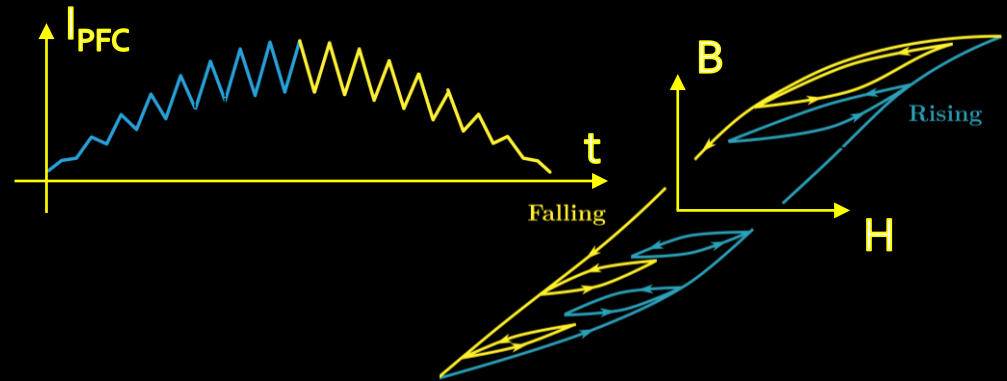

e.g., Inverter / Drive / PFC / PA / WPT

iGSE often under/over-estimate core losses for PFC inductors by 30%~50%

*across different switching frequencies, amplitudes, waveforms, temperatures, for specific materials



Diego Serrano



Haoran Li



Shukai Wang



Hyukjae Kwon

MagNet Database

data, data, data

Language (2005)

WordNet

A Lexical Database for English
by Princeton 



Image (2009)

IMAGEGENET

by Princeton 

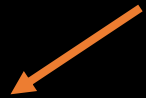

Magnetics (2020)

IEEE pels Challenge MagNet

by Princeton 

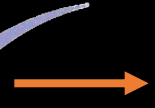

- largest open-source database
- >20 commonly used materials
- <1.2 seconds per data point
- >10,000 hrs of measurement time



Diego Serrano



Thomas Guillod

MagNet Data Quality

data quality -> model quality

Systematic Error [%]

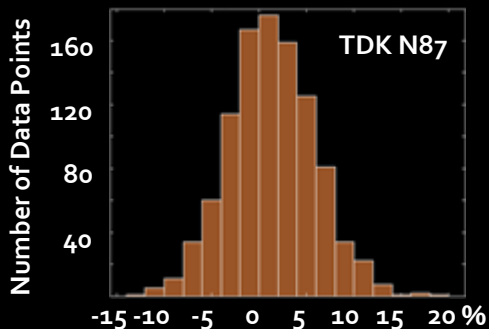

- Amplitude error
 - Voltage bias/gain
 - Current bias/gain
- Phase error
 - Voltage delay
 - Current delay
- Parasitic capacitance
- Temperature drift
- ...

Statistical Error [%]

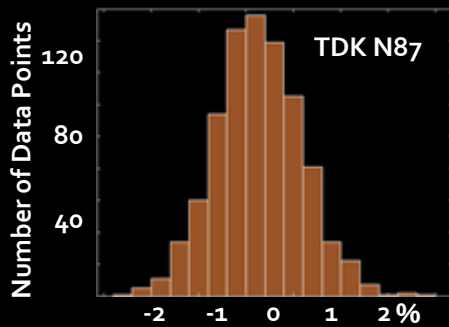

- Amplitude noise
 - Voltage noise
 - Current noise
- Phase noise
 - Voltage noise
 - Current noise
- Quantization error
- Core geometry error
- ...

Frequency limited

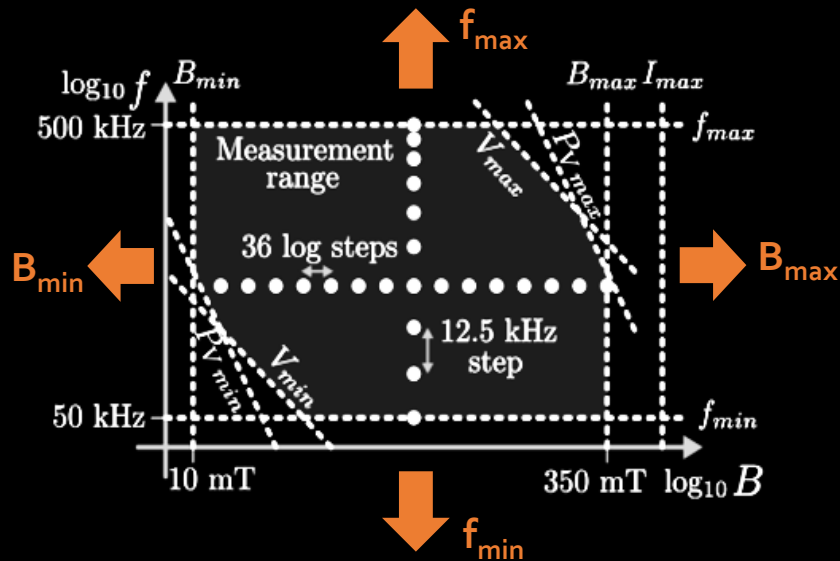

Amplitude limited



Charles R. Sullivan



Minjie Chen

MagNet Philosophy

... power electronics state machine ...

Large-Language Models (LLM)

The model is simply trained to predict the next word

current state + excitation = response

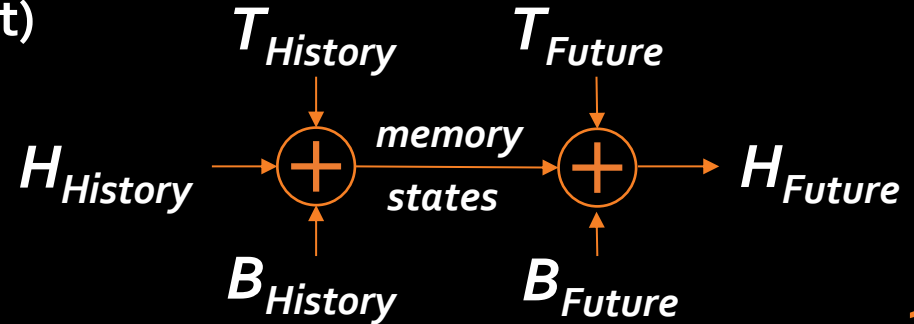
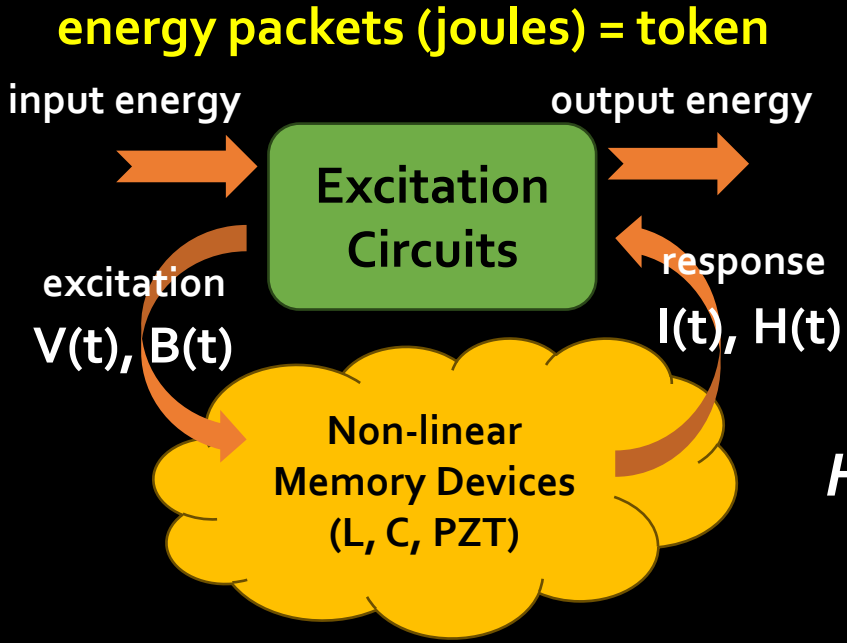

AI Accelerated PE Design

... we are just at the beginning ...



Human understandable models:

- Compact, explainable, insightful, intuitive, low dimensional

Machine accelerated tools:

- Sophisticated, powerful, accurate, versatile, high dimensional

MagNet World Cup

Model Size #

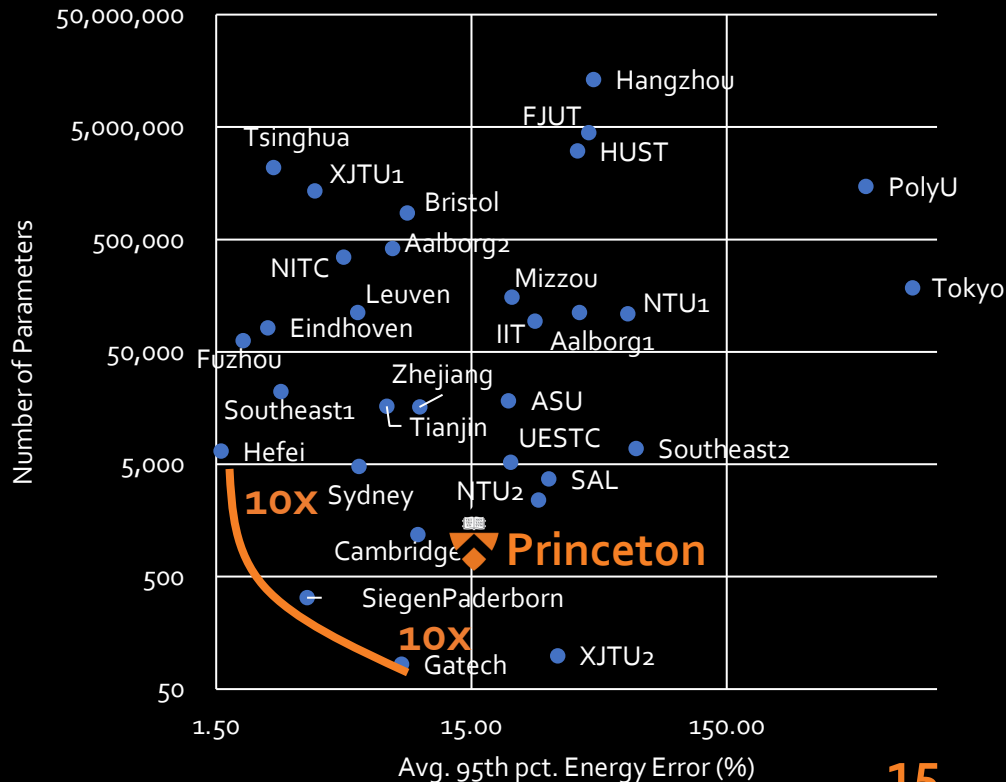
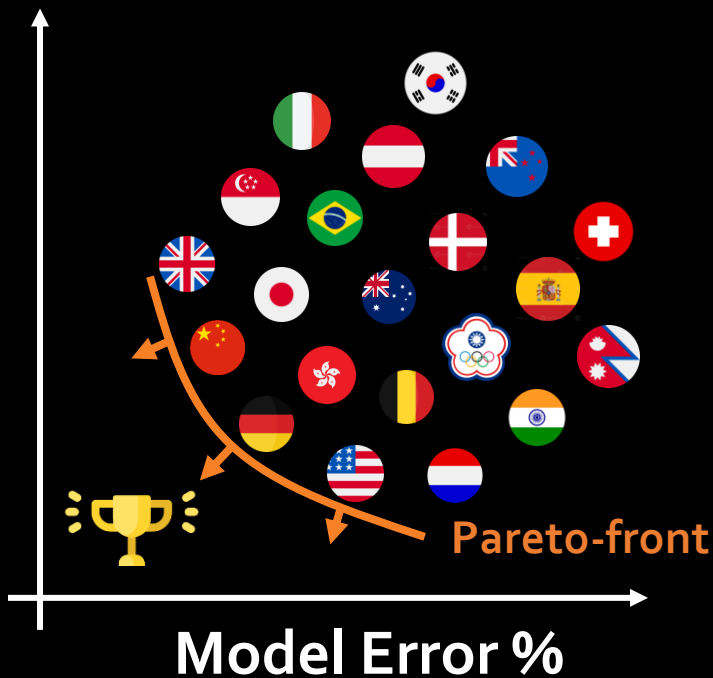

MagNet Challenge 2 Winners

Performance Track (\$18,000 + GPU)

1. Siegen & Paderborn (Germany)
2. Hefei & CityU & Xiamen (China)
3. Sydney (Australia)

Software Engineering Track (\$5,000):

- Hefei & CityU & Xiamen (China)

Honorable Mention (\$11,000 = \$1,000 x 11):

- Tianjin, Zhejiang, UESTC, Southeast1, Fuzhou, Eindhoven, Bristol, ASU, Leuven, Tsinghua, Mizzou

Innovation Track (\$18,000 + GPU)

1. Georgia Tech (USA)
2. Cambridge (UK)
3. Silicon Austria Labs (Austria)



\$52,000 USD + 2 NV GPUs

MagNet Award Ceremony



MagNet Award Ceremony

Tuesday, March 24, 1:30PM-3:00PM

Grand Hyatt Hotel, Lone Star C Room

Zoom: https://princeton.zoom.us/webinar/register/WN_OZpYzauSQBqCYx33SbsxnO

TC10 Meeting (MagNet 3)

Tuesday, March 24, 10:00AM-11:00AM

Grand Hyatt Hotel, Lone Star E Room

Zoom: https://princeton.zoom.us/webinar/register/WN_gwJxZho_RgS56mRfPdwnRA

Many IEEE/PSMA meetings ...

<https://apec-conf.org/attendees/power-electronics-society-meetings/>



MagNet + X

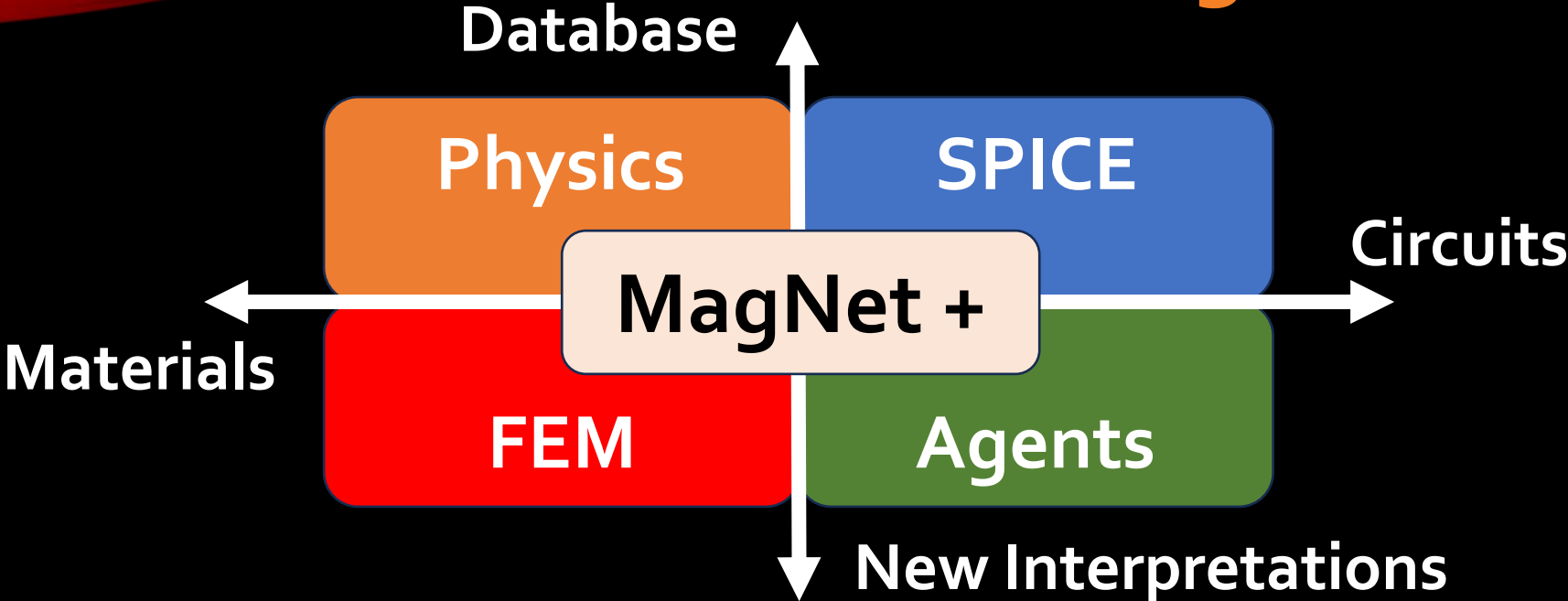

AI for Accelerated Design in Power Electronics

MagNet + Physics

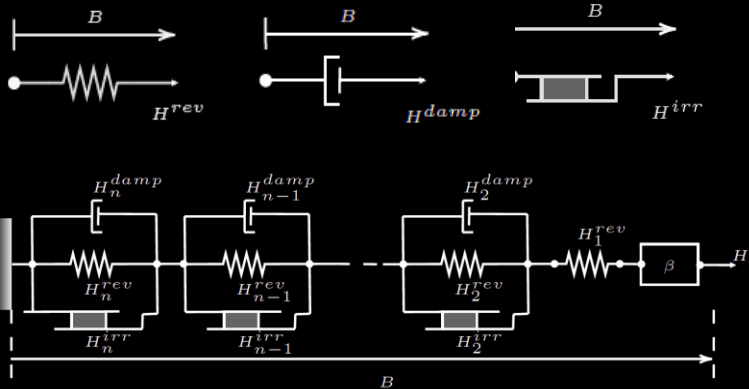

- Physics-informed interpretations
- MC2 Innovation Track, 1st Place

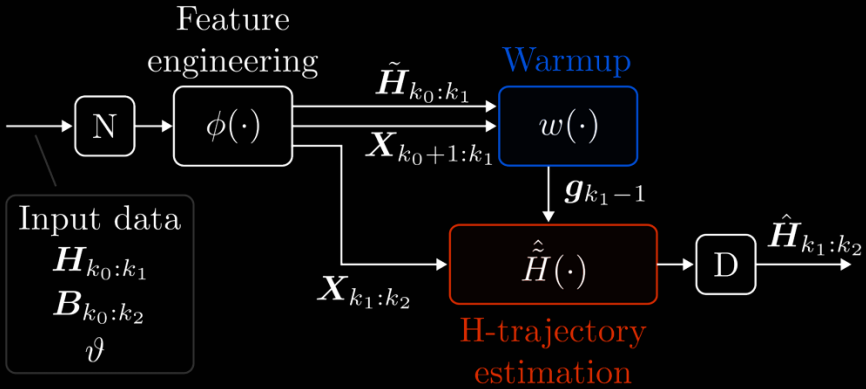

- Physics-informed implementations
- MC2 Performance Track, 1st Place

MagNet + SPICE

Hefei-CityUHK-Xiamen



HONG KONG

- MC2 Performance Track 2nd Place
- Best Software Engineering Award

Operating Conditions

Topology & Power

DC-AC Topology: Single-Phase Full Bridge

DC Voltage: 400V

Frequency: 7500Hz

Filter L: 1mH

Filter C: 2uF

Grid Parameters

Residential Industrial Weak Grid

Grid Voltage (Line voltage for three-phase): 220V

Grid Frequency: 50Hz

Power: 15000W

Grid Impedance: 0.5Ω

Harmonics Injection (%)

3rd: 1% 5th: 0.5% 7th: 0.3%

Power Control Parameters

Kp: 0.00004 Ki: 0.8

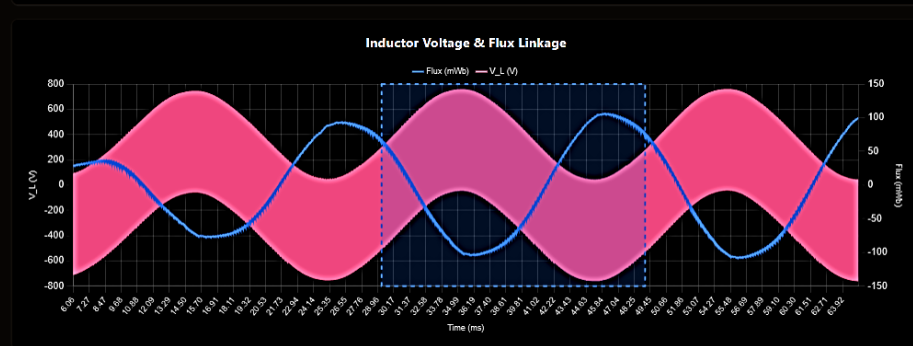
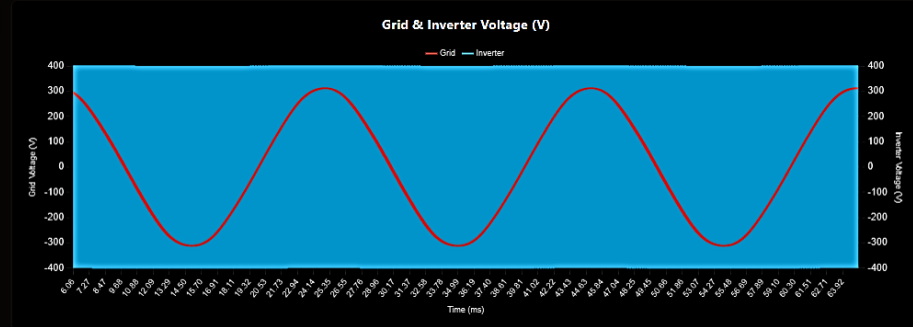

<https://u2802747-b031-2c6ccc63.westb.seetacloud.com:8443/>

MagNet + FEM



香港科技大學
THE HONG KONG
UNIVERSITY OF SCIENCE
AND TECHNOLOGY

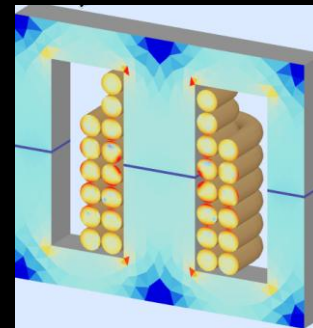
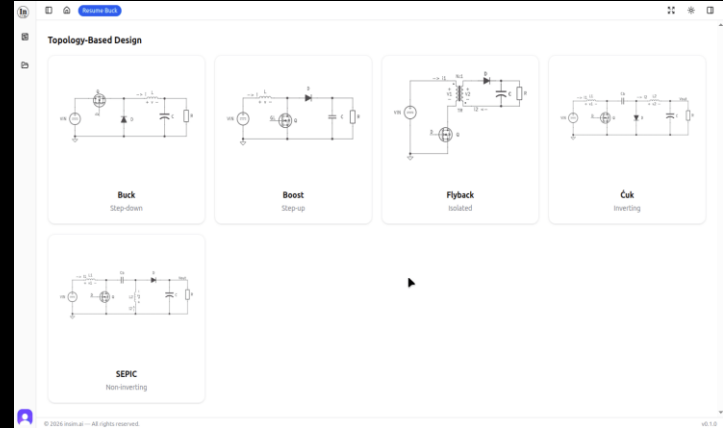
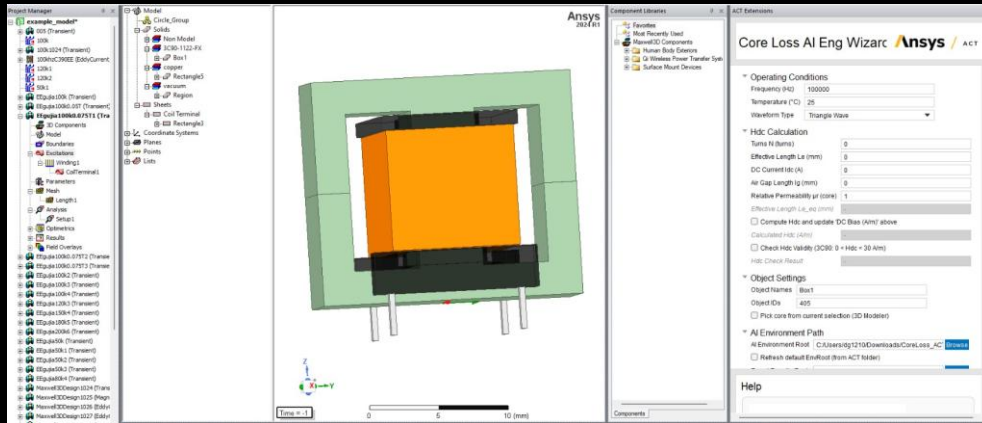

<https://insim.ai/>



21

Fuzhou University + HKUST + ANSYS
Performance Track 2nd Place, MagNet Challenge 1

MagNet + Agents



- Data
- Model
- Algorithm
- Tool
- Design rule
- Manufacturing



OpenClaw

- MagNet-Claw
- Circuit-Claw
- System-Claw

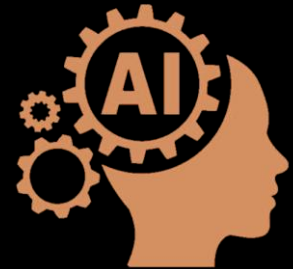

70% power magnetics
designed by AI before 2040?

MagNet + People



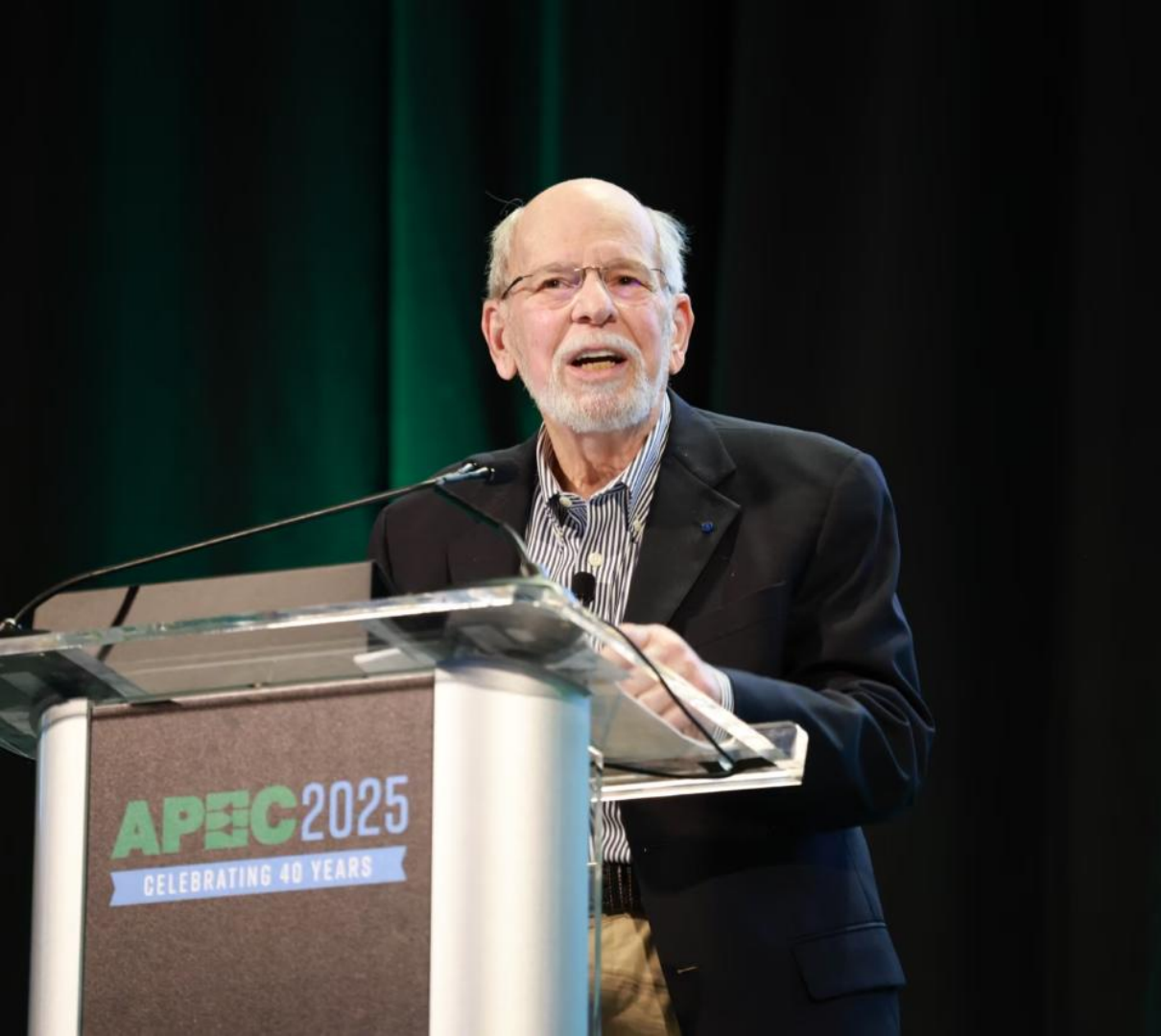

APEC

IS WHERE
MAGIC
HAPPENS!

